

salva



modular **NXE-2006-B2-V2 S530 Future**

FEATURES

Electrical polyvalent oven for trays formed by two modules or independent chambers apilables that allow to mount the oven so that it adapts to the current and future needs of the client.

STRUCTURE

■ Two bread doors per module

The glass is easy to replace and also to clean

■ Allogenic lighting

■ Bolinig Chamber

Fixed.

Aluminized sheets in the oven sides.

Stone sole and black blued steel ceiling.

■ High density insulation

■ Future Control Panel

It allows adapting the program to te baked product, controlling the percentage of heating elements, the steam injection time, the temperatura and the bakeing time.

■ Steam

Rapid recovery steam producer.

NEWS

Lower consumption ■

The POWER MASTER CONTROL system allows it to operate 33% bellow nominal power.

Better baking ■

The system of electrical resistances crossing the ceramic bricks, the heart of the SALVA modular oven, ensures excellent baking.

More programs ■

The new control panel has up to 100 different programs allowing different baking phases.

Temperature ■

The cooking temperature is up to 570°F due to the additional reinforcement of the baking chamber

OVEN COMPOSITION AND DETAILS

1 Top module

Essential.
Height: 6.5"

3 Base

Essential.
Height: 5.9"

4 Support NXE-530/02

Legs height: 20.9".
Wheels height: 8".

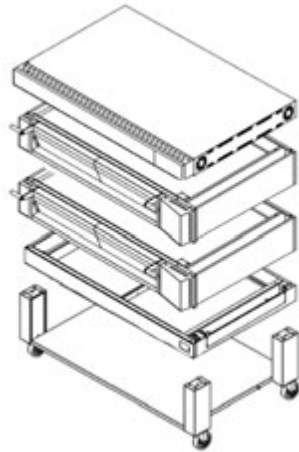

1

2

3

4

2

Two modules NXE-B1-V1
Height: 12.4"/module.
Capacity: 3 tray (26"x18")
Total capacity: 6 tray (26"x18")

	Total kW	V	A	Hz	BOCPD
NXE-B1-V1 Single Connection	10.9 kW 3Ph+G	204-240	28.2	50/60	35 Amp.
NXE-B1-V1 Single Connection	10.9 kW 3Ph+G	204-240	28.2	50/60	35 Amp.
Total Connection	21.9 kW 3Ph+G	204-240	56.4	50/60	70 Amp.

Weight: 1698 lbs

INSTALLATIONS IN DETAIL

A Baking chamber fumes chimney

It is recommendable to use a standard independent insulated damper of 7.9" (200 mm) inside diameter.

B Water supply

Outlet water pressure between 21 and 36 psi. End of the tube with 1/2" (23.3mm) male connector. Connection to the oven by 3/8" (10mm) minimum internal diameter flexible hose.

C Electric power supply

The electrical connection should be performed by authorized professionals, following the rules in force in each country.

D Water supply

Essential in modules with steam.
1" (33.7 mm) tube of metal or heat-resistant material.
Connection to the oven by 9/16" (14 mm) internal diameter flexible hose.

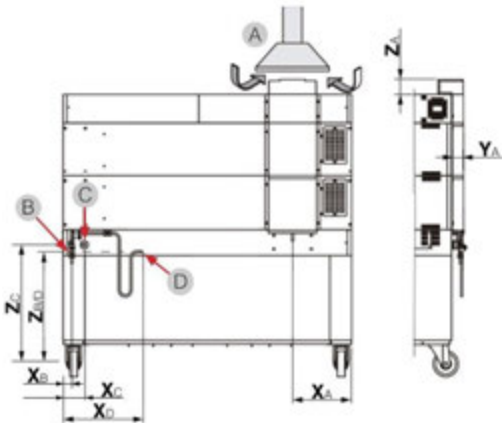

GENERAL DIMENSIONS

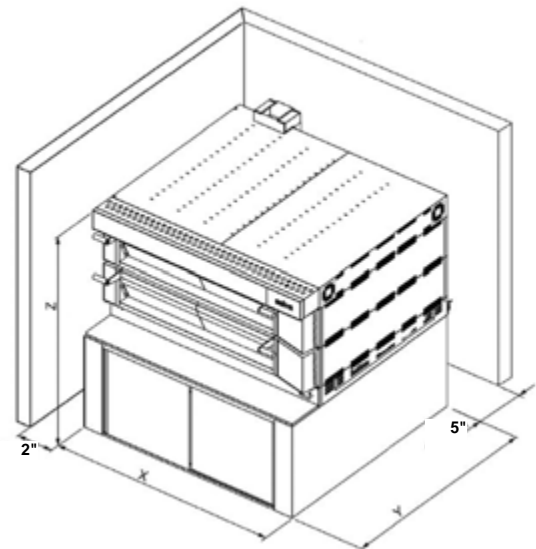

X	Y	Z
75.3 inch	52.4 inch	65.9 inch

Facilities location (in.) ■

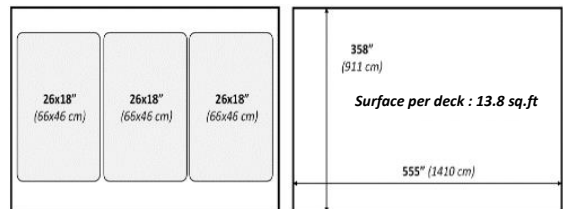

Surface per deck: 13.8 sq.ft

Capacity per deck: 3 tray (26" x 18")

	X	Y	Z
A Baking chamber fumes chimney	13.9"	2.9"	3.8"
B Water supply	2.4"	-	29"
C Electric power supply	4.7"	-	27.4"
D Drainage	4"	-	29"